



CNC LATHES N SERIES

TNC - 06N/08N

WITH MITSUBISHI CONTROLLER

- *ECONOMICAL*
- *SPEEDY*
- *SIMPLIFIED*
- *EASY MAINTENANCE*
- *HIGH EFFICIENCY*

CNC-TAKANG

CNC-TAKANG CO., LTD.
MANUFACTURER & EXPORTER

TNC-SERIES

■ GANG TOOL SYSTEM

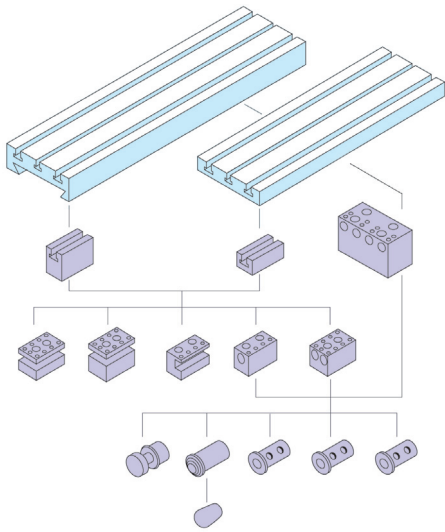

■ DIMENSION (mm)

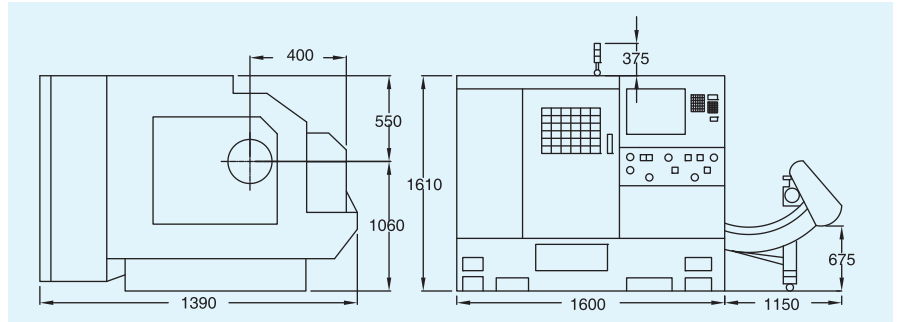

TNC-06N

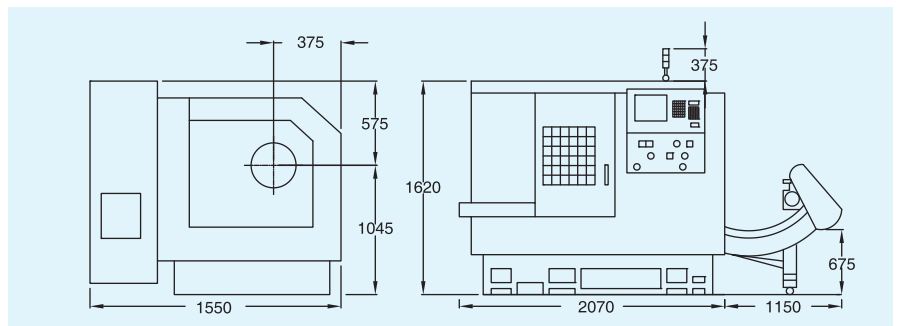

TNC-08N



TNC-08N



TNC-06N

■ TURRET TOOL SYSTEM

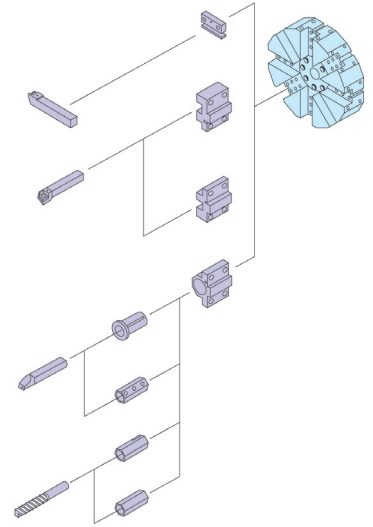

■ WORK RANGE

TNC - 08N
(With tailstock)

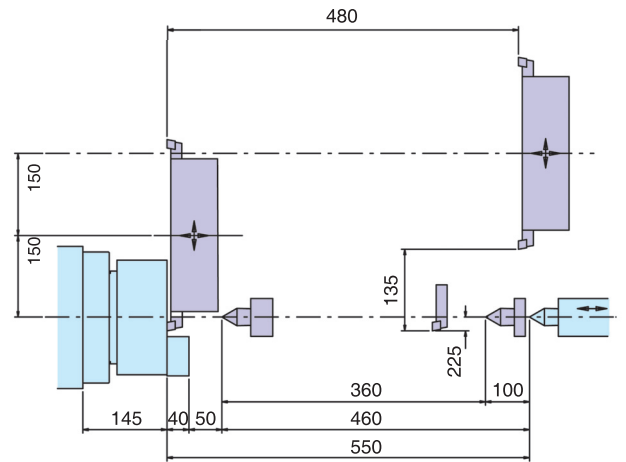

■ TURRET TOOLS INTERFERENCE (mm)

TNC - 06N (08N)

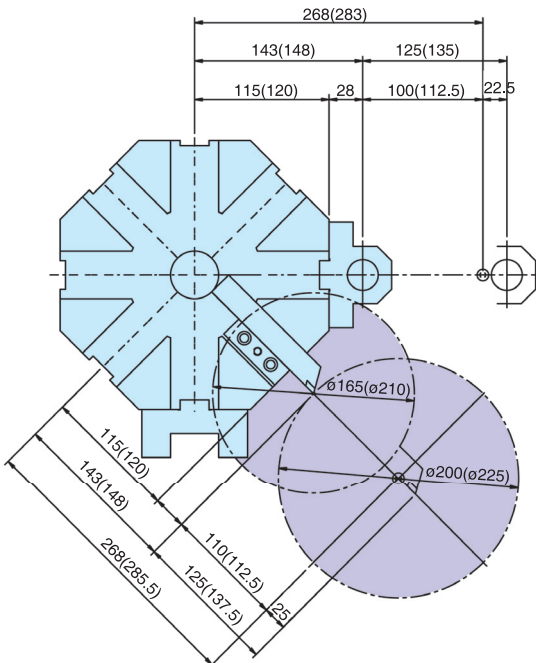

TNC - 06N

TNC - 08N

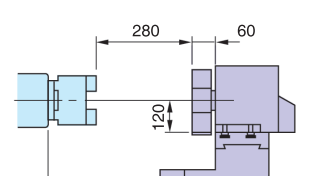
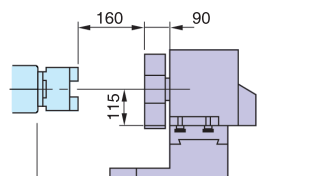
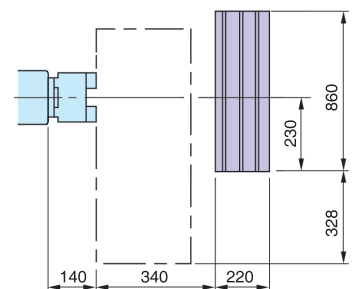
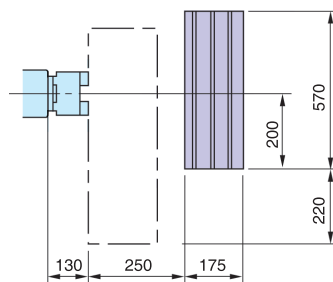

SPECIFICATIONS

MODEL	DESCRIPTION	TNC-06N	TNC-08N
Capacity	Swing over bed	400 mm	400 mm
	Swing over saddle	160 mm	200 mm
	Distance between center	–	400 mm
	Cutting diameter / length	ø 130 / 160 mm	ø 200 / 480 mm
	Hydraulic chuck	6"	8"
	Bar capacity	ø 42 mm	ø 52 mm
	Bed width	220 mm	320 mm
	Bed slant angle	25°	20°
Spindle	Spindle nose	A2-5	A2-6
	Spindle hole	55 mm	60 mm
	Spindle speed	100 - 6000 rpm	100 - 4000 rpm
	Spindle motor	7.5 HP	10 HP
	Spindle OD diameter	ø 85 mm	ø 100 mm
Turret (Option)	Turret type	Hydraulic	Hydraulic
	Tool station	8	8
	Tool holder size	ø25 mm, □20 mm	ø32 mm, □25 mm
Travel	X Travel	230 mm	320 mm
	Z Travel	300 mm	560 mm
	Rapid travel	16 M / Min.	12 M / Min.
Tailstock (Option)	Tailstock travel	–	360 mm
	Quill taper	–	MT4
	Tailstock diameter	–	ø 53 mm
	Quill travel	–	100 mm
Motor	Servo motor (X)	1HP (HA 40)	1HP (HA 40)
	Servo motor (Z)	1HP (HA 40)	2HP (HA 80)
	Coolant pump	1/4 HP	1/4 HP
	Hydraulic motor	1 HP	1 HP
Weight	Kgs	1780	3000
Machine Size	L x W x H mm	2440 x 1260 x 1830	3200 x 1860 x 1850

※THE SPECIFICATIONS ARE SUBJECT TO CHANGE WITHOUT PRIOR NOTICE.

STANDARD ACCESSORIES:

1. Mitsubishi M80 controller
2. 6" hydraulic hollow chuck & cylinder (TNC-06N)
8" hydraulic hollow chuck & cylinder (TNC-08N)
3. Toolpost & sleeve
4. Sub-plate
5. Auto coolant, hydraulic & lubrication system
6. Work light
7. Chip conveyor (only for TNC-08N)
8. Tool box with tools and manuals

OPTIONS:

1. Spindle orientation with 15 degree index
2. 8 stations hydraulic turret
3. Collet chuck and collets
4. Auto door
5. Chuck air cleaner
6. Milling attachment
7. Parts catcher
8. Chip conveyor (TNC-06N)
9. Bar feeder
10. FANUC 0i-TF plus
11. CE Mark

CNC-TAKANG CO., LTD.

No. 72, Alley 7, Lane 98, 1st Road, Taichung Industry Park,
Taichung 40767, TAIWAN
FAX: +886-4-2359 6064 E-mail: takang@ms17.hinet.net
TEL: (04)2359 6056 Web site: www.cnctakang.com.tw