



CNC VERTICAL LATHE (HIGH SPEED Series)

TKV - 460H / TKV - 760H
TKV - 860H / TKV - 1100H

TWIN MACHINE (T) & MILLING FUNCTION (M)
ALSO AVAILABLE

CNC-TAKANG

CNC-TAKANG CO., LTD.
MANUFACTURER & EXPORTER

High Speed Series
VT

TKV-460H Series



**TKV-460H
with V4 turret (Option)**



**TKV-460HT
Twin type with
H12+H12 turrets**

TKV-760H / 860H / 1100H Series



TKV-760H
with V4 / V6 turret (Option)



TKV-860H



TKV-1100H

TKV-460H / 760H / 860H / 1100H



H12 Turret with milling (Turning)



H12 Turret



H12 Turret (Drilling)

■ OPTIONS



Second control box



Coolant system (3 bar and more)



High and low pressure of hydraulic chuck



Air condition for electrical cabinet



Special chuck (Options)



Tool presetter



Oil mist collector

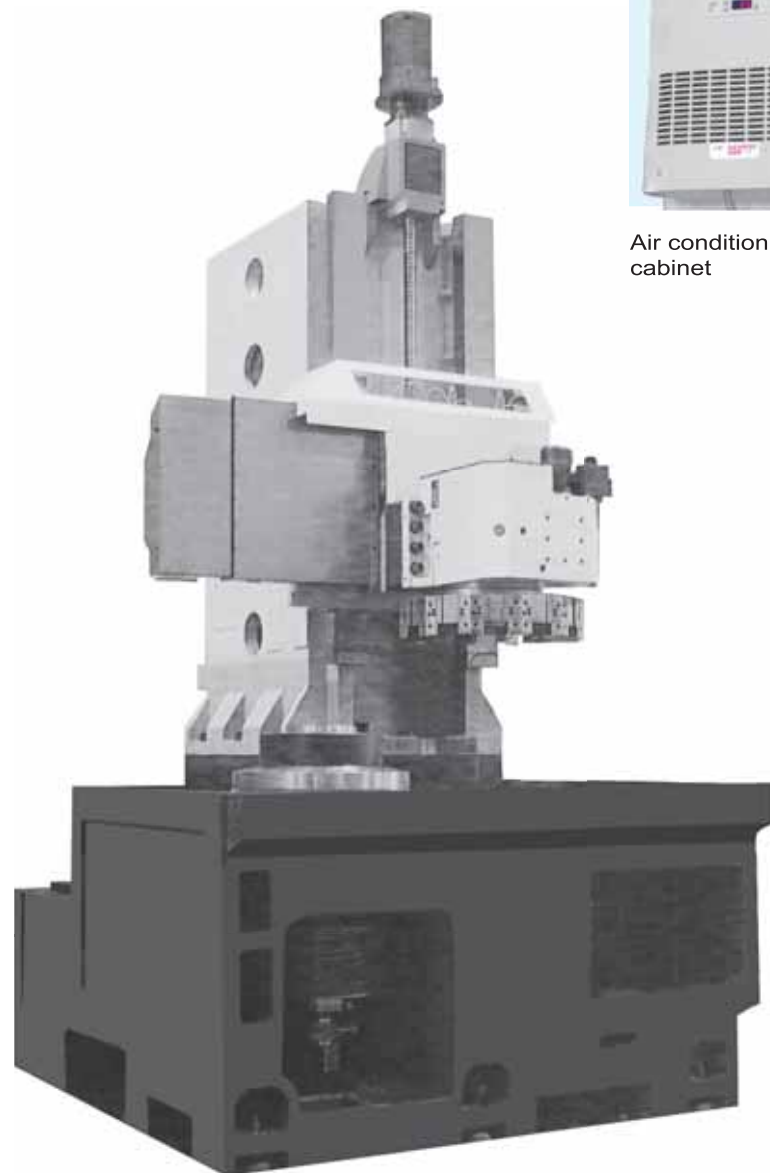

V6 Turret



External counter for each insert



Oil skimmer (Disk type)



High torque main spindle motor with built-in dual speed gearbox



V4 Turret



Finger hydraulic chuck



Simultaneous double tooling device

TKV-460H / 760H / 860H / 1100H

Table-speed and torque

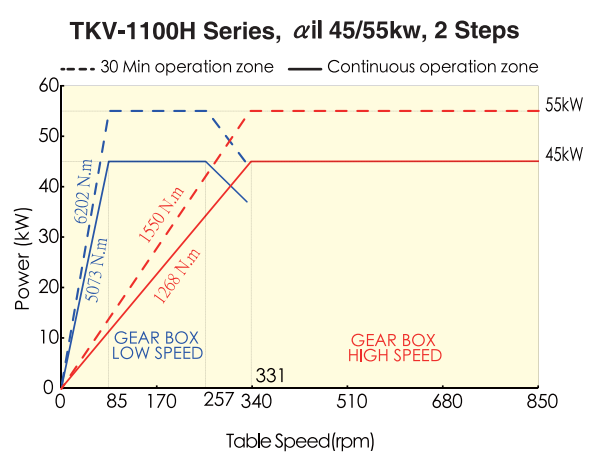
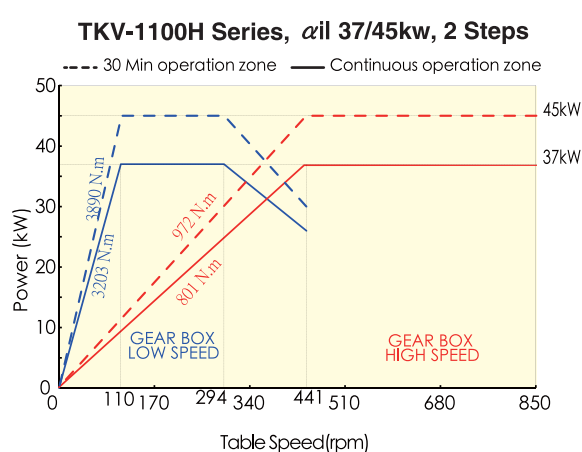
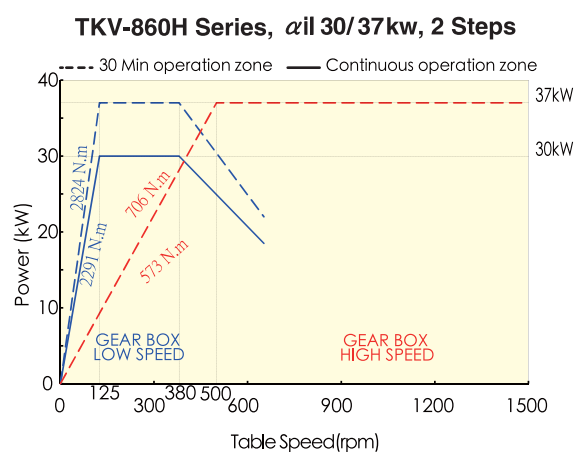
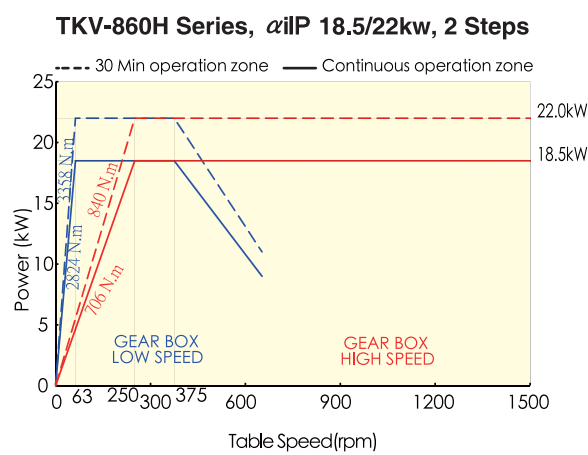
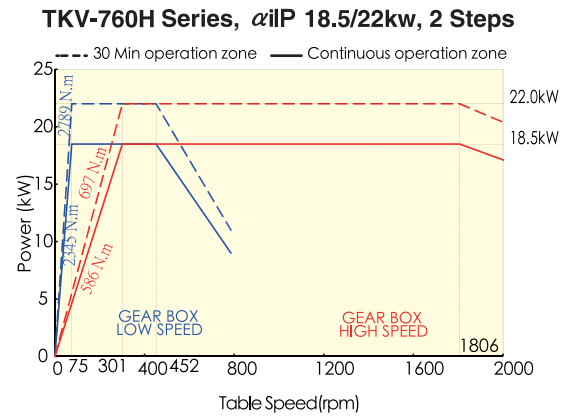
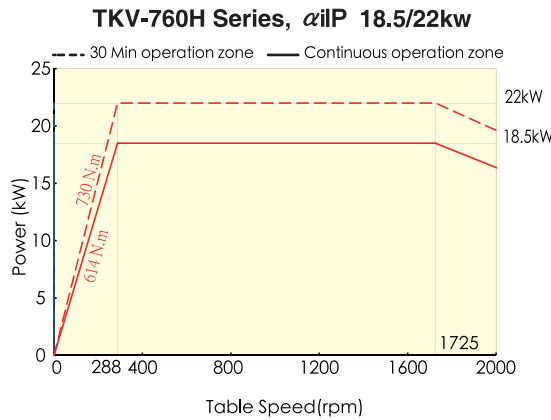
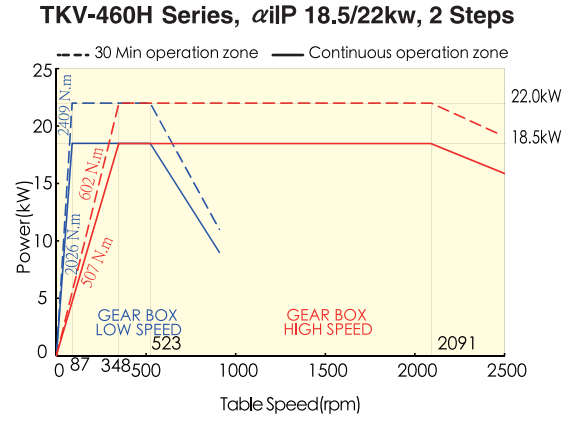
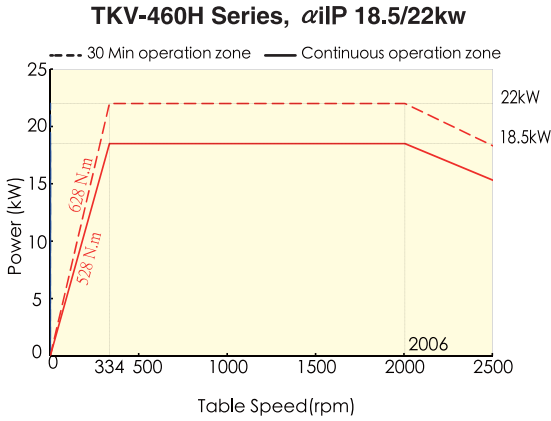

TKV-460H / 760H / 860H / 1100H

■ DIMENSIONS (Unit: mm)

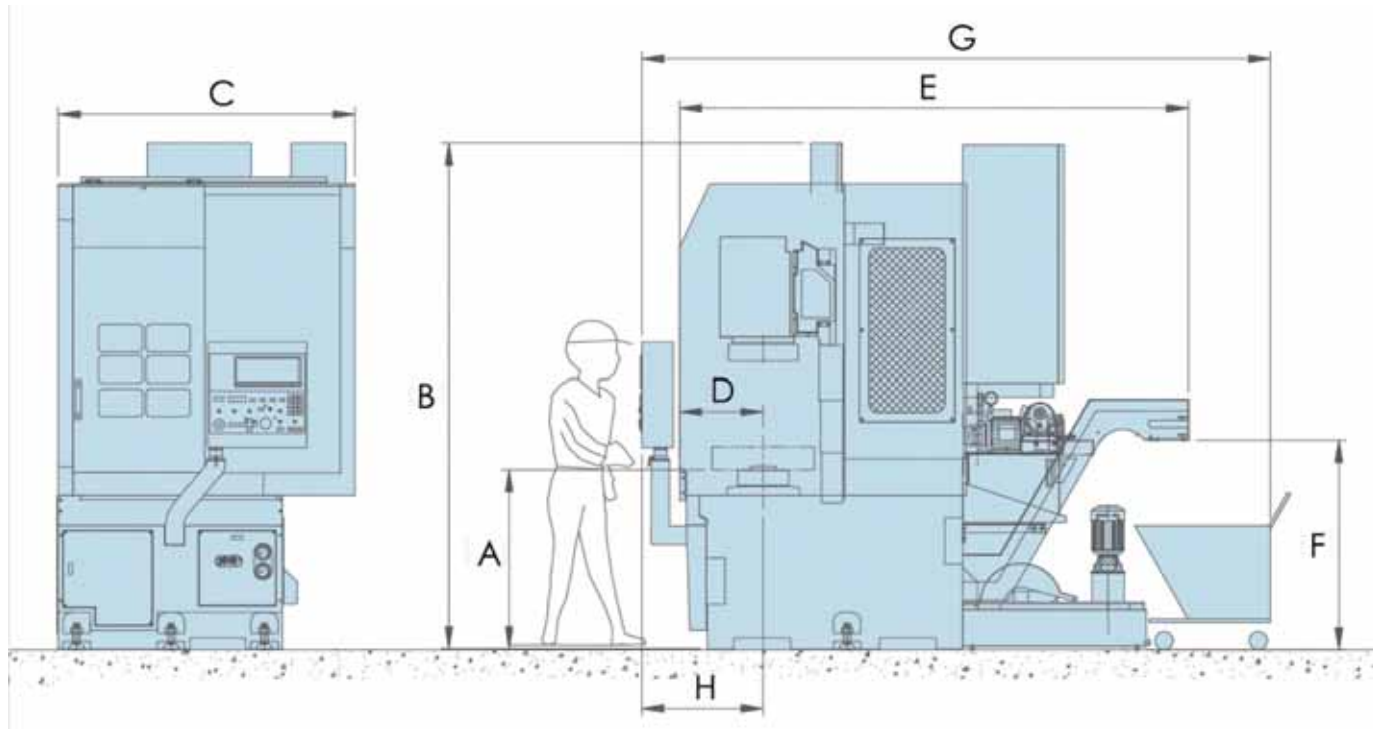

	A	B	C	D	E	F	G	H
TKV-460H	990	2855	1620	457	2780	1140	3430	650
TKV-760H	1080	3440	1950	505	2980	1200	3670	710
TKV-860H	1200	3900	2100	655	3288	1200	3870	860
TKV-1100H	1250	4042	2710	755	3700	1250	4230	1030
TKV-460HM	990	2815	1620	457	2780	1140	3430	650
TKV-760HM	1080	3450	1950	505	2980	1200	3670	710
TKV-860HM	1200	3872	2100	655	3288	1200	3870	860

(Option: V4 / V6 / V8)

	A	B	C	D	E	F	G	H
TKV-460H	980	2950	2220	400	2670	975	3435	630
TKV-760H	1175	3680	2070	575	3180	1015	3855	845
TKV-860H	1175	4000	2070	575	3180	1015	3855	845
TKV-1100H	1250	4042	2710	755	3700	1250	4230	1030

■ STANDARD TOOLING SYSTEM (H12 TURRET) (Unit: mm)

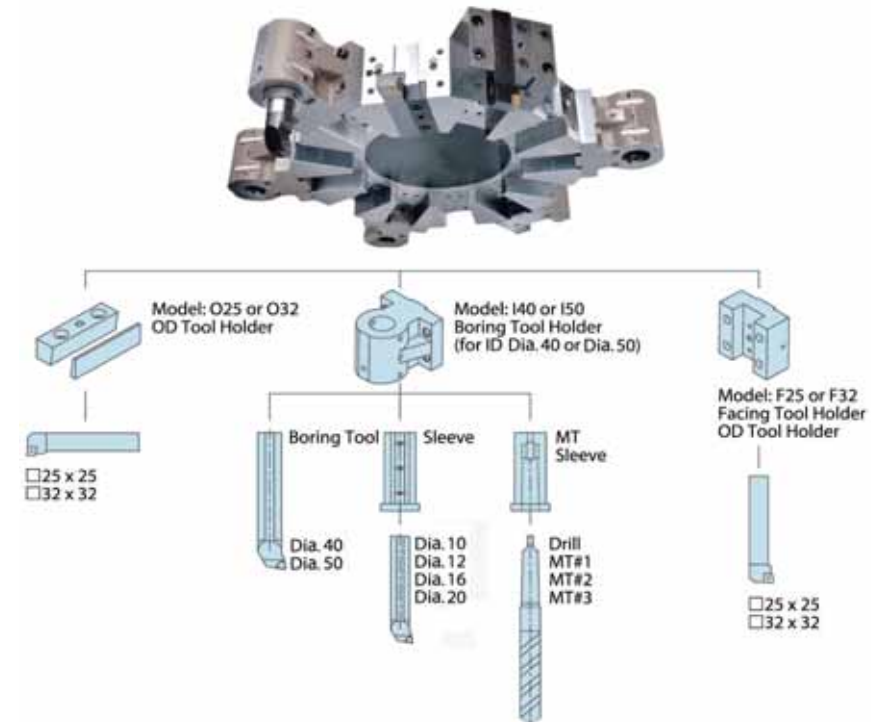

■ STANDARD TOOLING SYSTEM (H12 TURRET WITH MILLING) (Unit: mm)

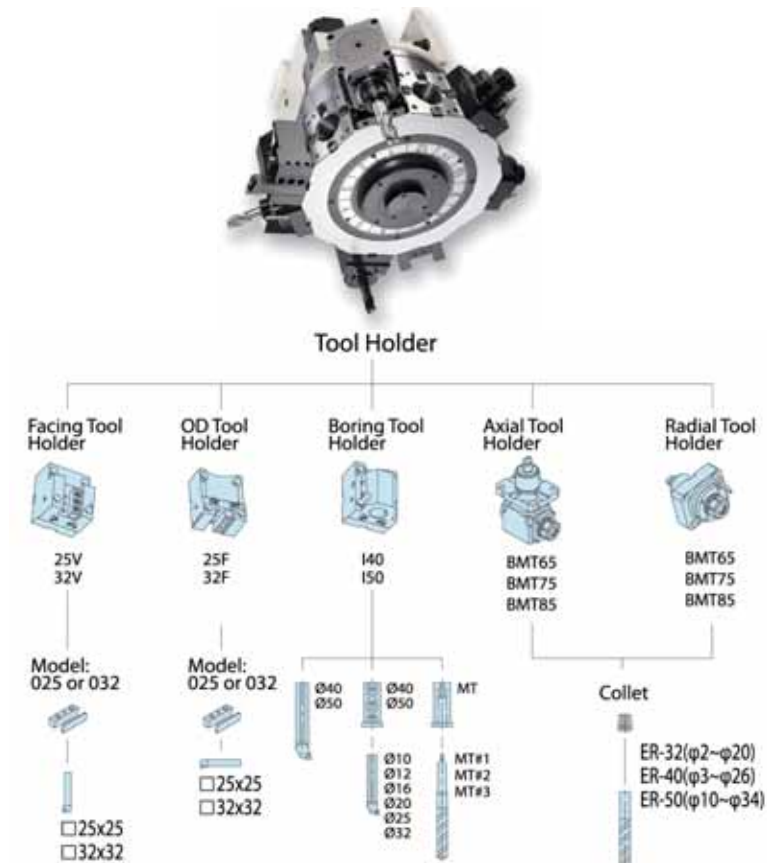

■ ELECTRICAL CABINET



- Easy maintenance circuit arrangement.
- Suitable all kinds of environment.
- CE standard available.

■ CNC CONTROLLER



Fanuc Oi-T



Siemens 840D

■ **WORK RANGE: H12 TURRET** (Unit: mm)

TKV-460H

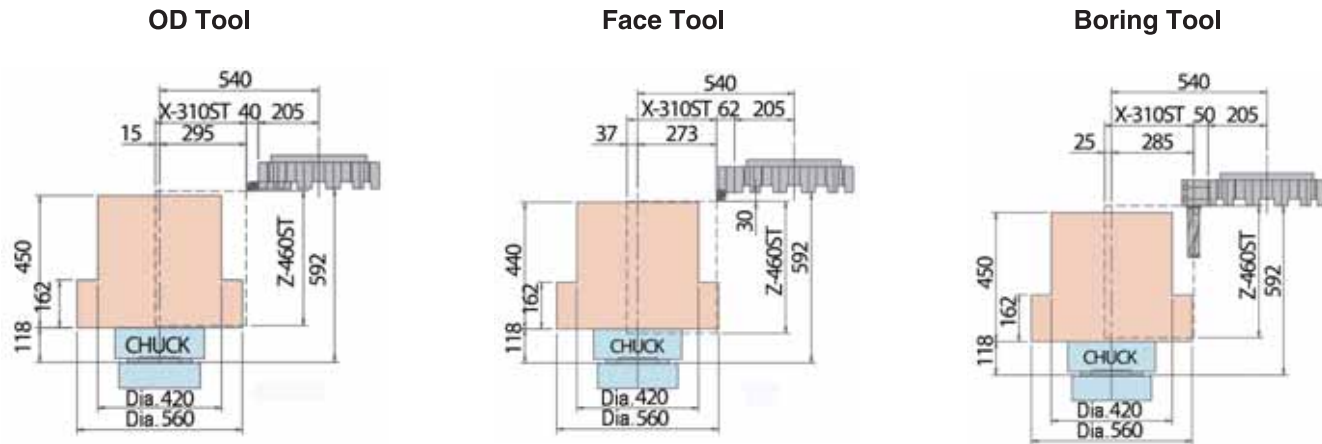

TKV-760H

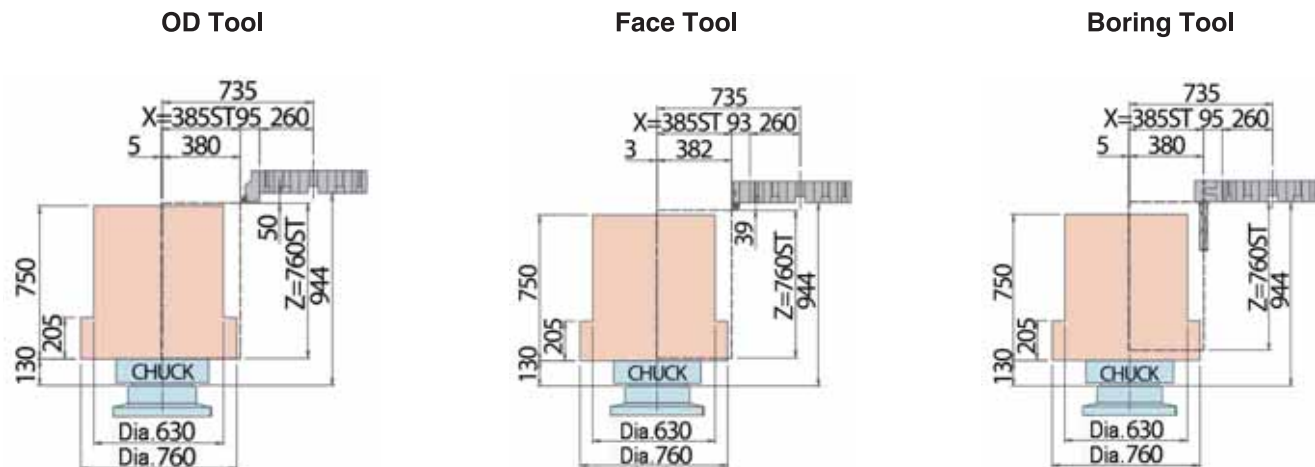

TKV-860H

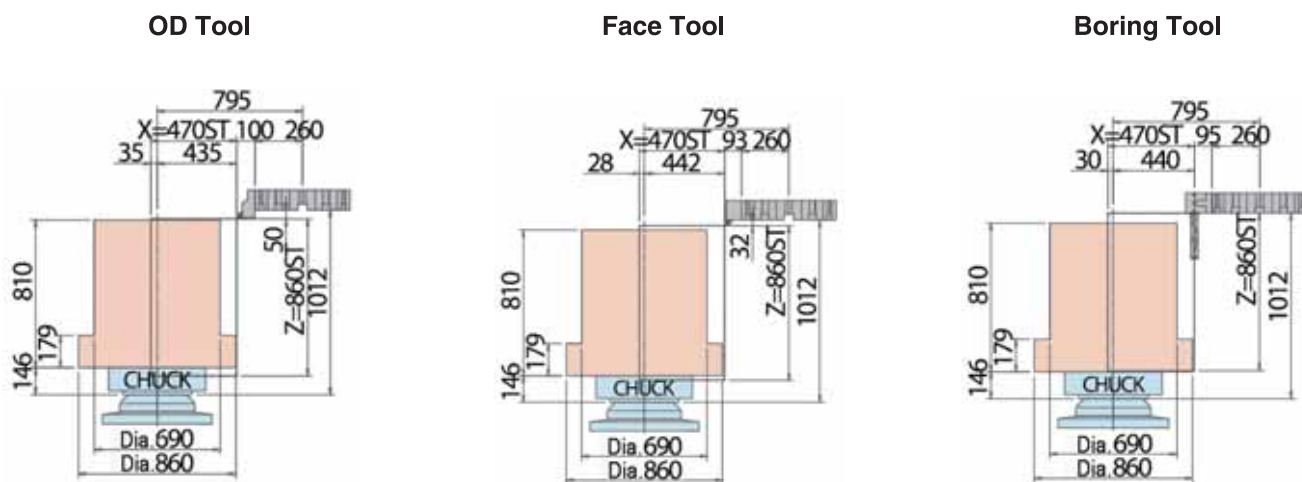

TKV-1100H

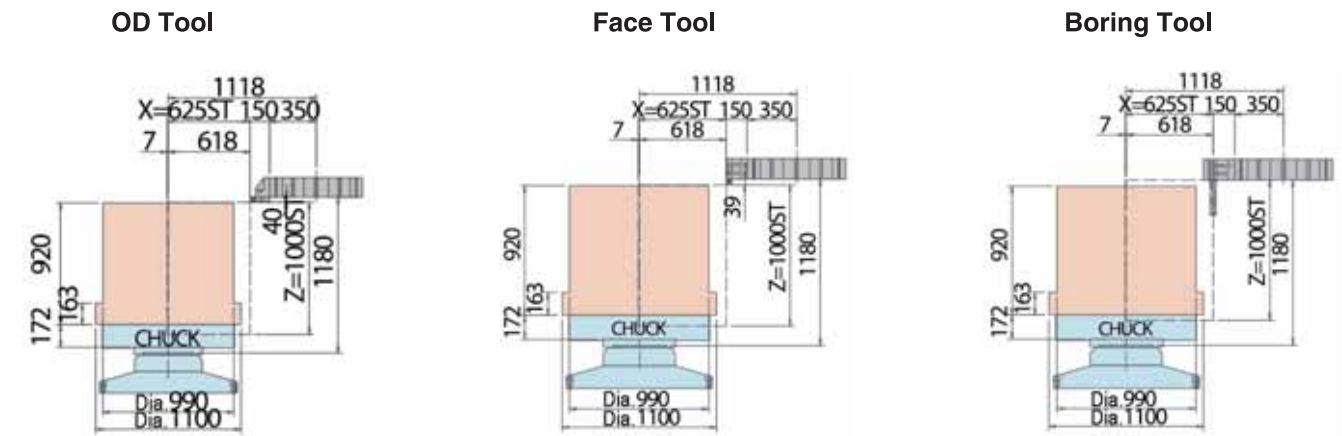

■ **TOOL INTERFERENCE: H12 TURRET** (Unit: mm)

TKV-460H (H12)

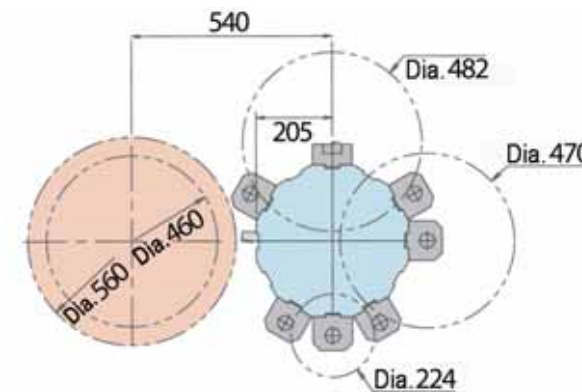

TKV-760H (H12)

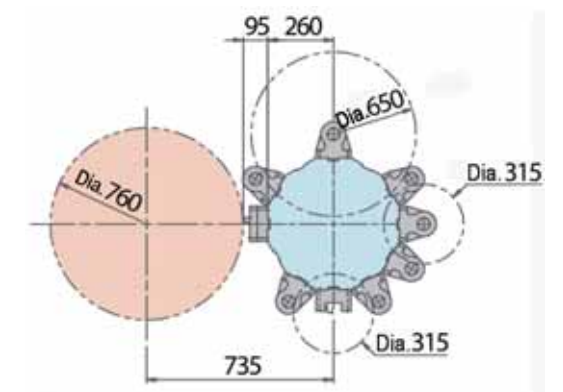

TKV-860H (H12)

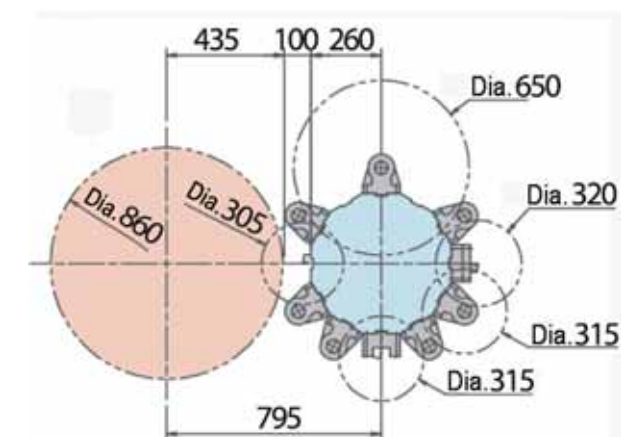

TKV-1100H (H12)

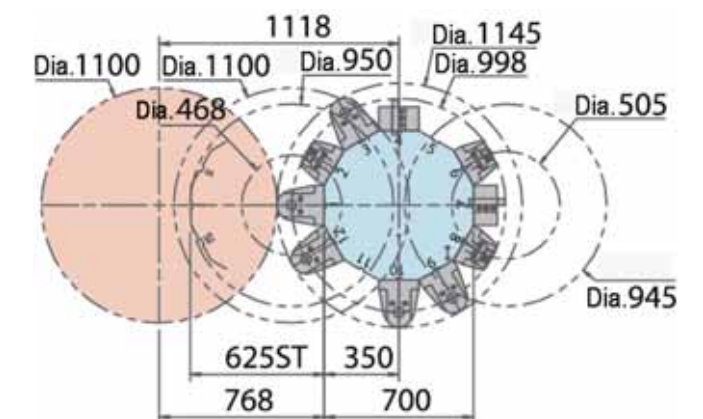

SPECIFICATIONS

MODEL	DESCRIPTION	TKV-460H	TKV-460HT	TKV-460HM	TKV-460HMT	TKV-760H	TKV-760HT	TKV-760HM	TKV-760HMT	TKV860H	TKV-860HT	TKV-860HM	TKV-860HMT	TKV-1100H
Capacity	Max. swing dia.	560 mm (650 mm, V-type turret only)		560 mm		800 mm (850 mm, V-type turret only)				1000 mm				1320 mm
	Max. turning dia.	560 mm		560 mm		760 mm		700 mm		860 mm		800 mm		1100 mm
	Std. turning dia.	420 mm (560 mm, V-type turret only)		520 mm		630 mm (760 mm, V-type turret only)		700 mm		690 mm (860 mm, V-type turret only)		800 mm		990 mm
	Max. turning height	450 mm (400 mm, V-type turret only)		380 mm		750 mm (620 mm, V-type turret only)		650 mm		810 mm (800 mm, V-type turret only)		700 mm		920 mm
Spindle	Hydraulic chuck	305 mm (12")				457 mm (18")				533 mm (21")				1000 mm (40") / manual 4-jaw chuck
	Range of table speed	25-2500 rpm				25-2000 rpm				25-1500 rpm				5-850 rpm
	Front bearing dia.	120 mm				160 mm				200 mm				200 mm
	Spindle nose	A2-8				A2-11				A2-11 (OPT A2-15)				ISO702-4 No.15 (Dia. 380 mm)
Turret	Turret type	H12 (OPT V4 / V6 / V8)	H12+H12	H12	H12+H12	H12 (OPT V4 / V6 / V8)	H12+H12	H12	H12+H12	H12 (OPT V4 / V6 / V8)	H12+H12	H12	H12+H12	H12
	Number of tool position	12 (OPT 4 / 6 / 8)	12+12	12	12+12	12 (OPT 4 / 6 / 8)	12+12	12	12+12	12 (OPT 4 / 6 / 8)	12+12	12	12+12	12
	Tool size	□25, □32, Dia. 40 mm		□25, Dia. 40 mm		□25, □32, Dia. 40, Dia. 50 mm		□25, Dia. 40, Dia. 50 mm		□25, □32, Dia. 40, Dia. 50 mm		□25, Dia. 40, Dia. 50 mm		□32, Dia. 50 mm
Feed	Rapid rate (X-axis)	20 M / min				20 M / min				20 M / min				20 M / min
	Rapid rate (Z-axis)	20 M / min				20 M / min				20 M / min				20 M / min
	Horizontal travel (X-axis)	310 mm (-10+310 mm, V-type turret only)				385 mm (-50+550 mm, V-type turret only)				470 mm (-50+550 mm, V-type turret only)				625 mm
	Vertical travel (Z-axis)	460 mm (550 mm, V-type turret only)				760 mm (700 mm, V-type turret only)				860 mm (850 mm, V-type turret only)				1000 mm
	Cutting feed rate	0.001-500 mm / rev				0.001-500 mm / rev				0.001-500 mm / rev				0.001-500 mm / rev
	Feed override	0-150 %				0-150 %				0-150 %				0-150 %
Motor	Controller system	FANUC 0i-T				FANUC 0i-T				FANUC 0i-T				FANUC 0i-T
	Spindle motor (Cont./30min)	aiIP40 (18.5 / 22 kw)				aiIP40 (18.5 / 22 kw)				aiIP40 (18.5 / 22 kw)				aiI40 (37 / 45 kw)
	Feed motor (X-axis)	3 kw				4 kw				4 kw				4 kw
	Feed motor (Z-axis)	4 kw (7 kw, V-type turret only)				7 kw (4 kw, V-type turret only)				7 kw				7 kw
	Driving tool motor (Cont./30min)			3.7 / 5.5 kw				7.5 / 11 kw				7.5 / 11 kw		
Miscellaneous	Coolant tank	270 L				320 L				320 L				500 L
	Power requirement	40 KVA	75 KVA	45 KVA	85 KVA	40 KVA	75 KVA	45 KVA	85 KVA	40 KVA	75 KVA	45 KVA	85 KVA	80 KVA
	Floor space (L x W, mm)	1700 x 3100	3400 x 3100	1700 x 3100	3400 x 3100	1950 x 3410	3900 x 3410	1950 x 3410	3900 x 3410	2100 x 3500 (V-type turret only 1950 x 3500)	4200 x 3500	2100 x 3500	4200 x 3500	2700 x 4000
	Max. height	2855 mm				3450 mm				3900 mm				4050 mm
	Net weight	6500 kgs	13000 kgs	6600 kgs	13200 kgs	11500 kgs	23000 kgs	11600 kgs	23200 kgs	14500 kgs (V-type turret only 14600 kgs)	29000 kgs	14600 kgs	29200 kgs	21000 kgs

※THE SPECIFICATIONS ARE SUBJECT TO CHANGE WITHOUT PRIOR NOTICE.

STANDARD ACCESSORIES:

- Spindle orientation.
- Manual 4-jaw chuck (for TKV-1100H)
- Hydraulic 3-jaw solid chuck and cylinder, size as spec (except TKV-1100H)
- Hydraulic power unit
- Soft jaw x 1 set for hydraulic chuck (except TKV-1100H)
- Foot switch for hydraulic chuck (except TKV-1100H)
- Automatic lubrication system
- Coolant through turret
- Coolant flushing system with tank
- Heat exchanger for electrical cabinet
- Splash guard
- Work light
- Warning light (R / Y / G)
- Workpiece counter (CNC controller)
- Chain type chip conveyor and chip trolley
- Manual for operation and maintenance
- Manual for electrical and hydraulic circuit diagram
- Electronic manual for controller
- Tool box with tool kits
- Leveling bolts and pads

OPTIONS:

- Higher power motor, aiI30 (30 / 37 kw), aiI40 (37 / 45 kw), aiI50 (45 / 55 kw)
- Extra hydraulic chuck and cylinder (for TKV-1100)
- Dual speed gear box for main spindle
- High and low pressure chucking
- Chuck position sensor
- Hard jaw of chuck
- Manual guide i
- Oil mist collector
- Auto door
(Automatic opening and closing of main door)
- Special tool holder
- High pressure coolant through turret
- Tool presetter
- Turning tools
- External counter display for each insert
- Air condition for electrical cabinet
- Oil skimmer (Disk type)
- Scrap type chip conveyor with chip trolley
- Jig and Fixture
- Turnkey Project
- Power transformer
- CE mark

CNC-TAKANG CO., LTD.

No. 72, Alley 7, Lane 98, 1st Road, Taichung Industry Park, Taichung 40767, TAIWAN
 FAX: +886-4-2359 6064 E-mail: takang@ms17.hinet.net
 TEL: (04)2359 6056 Web site: www.cnctakang.com.tw