

SWISS TURN SERIES



SWISS TYPE CNC AUTO LATHES

S-125 / S-205N / S-206

S-265 / S-325

- Built-in main and back spindle motors
*higher synchronized spindle speed
better phase angle and machining accuracy*
- Swiss-type turning and milling lathe with double C axis.
Multiple complex machining

CNC-TAKANG

CNC-TAKANG CO., LTD.
MANUFACTURER & EXPORTER

Features

- Separate back tool post and cross travel back spindle
simultaneous machining on main spindle and back spindle to reduce cycle time
- 4 cartridge type live tools, 4 fixed tools for back tool post and Y2 axis
exchangeable with other live tool positions
exchangeable with other fixed tool position by adaptor
- Thread whirling head can be mount for bone screws / long threads processing

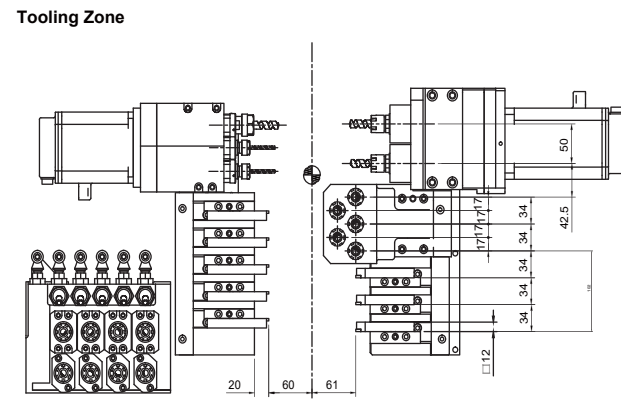

Floor Space

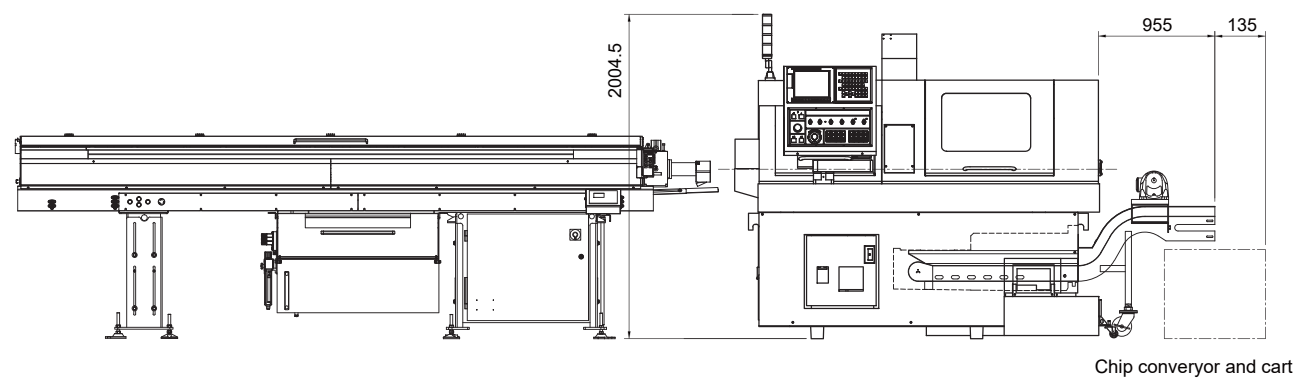
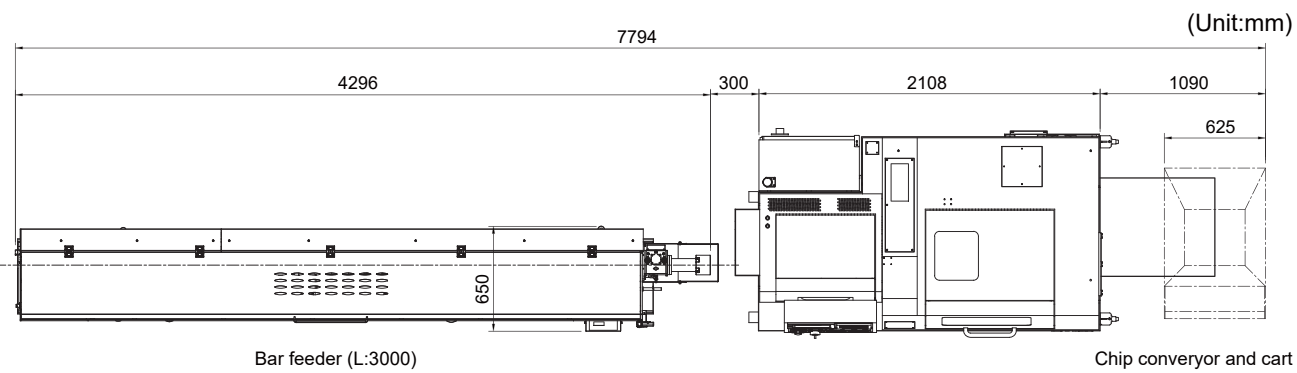

S-125

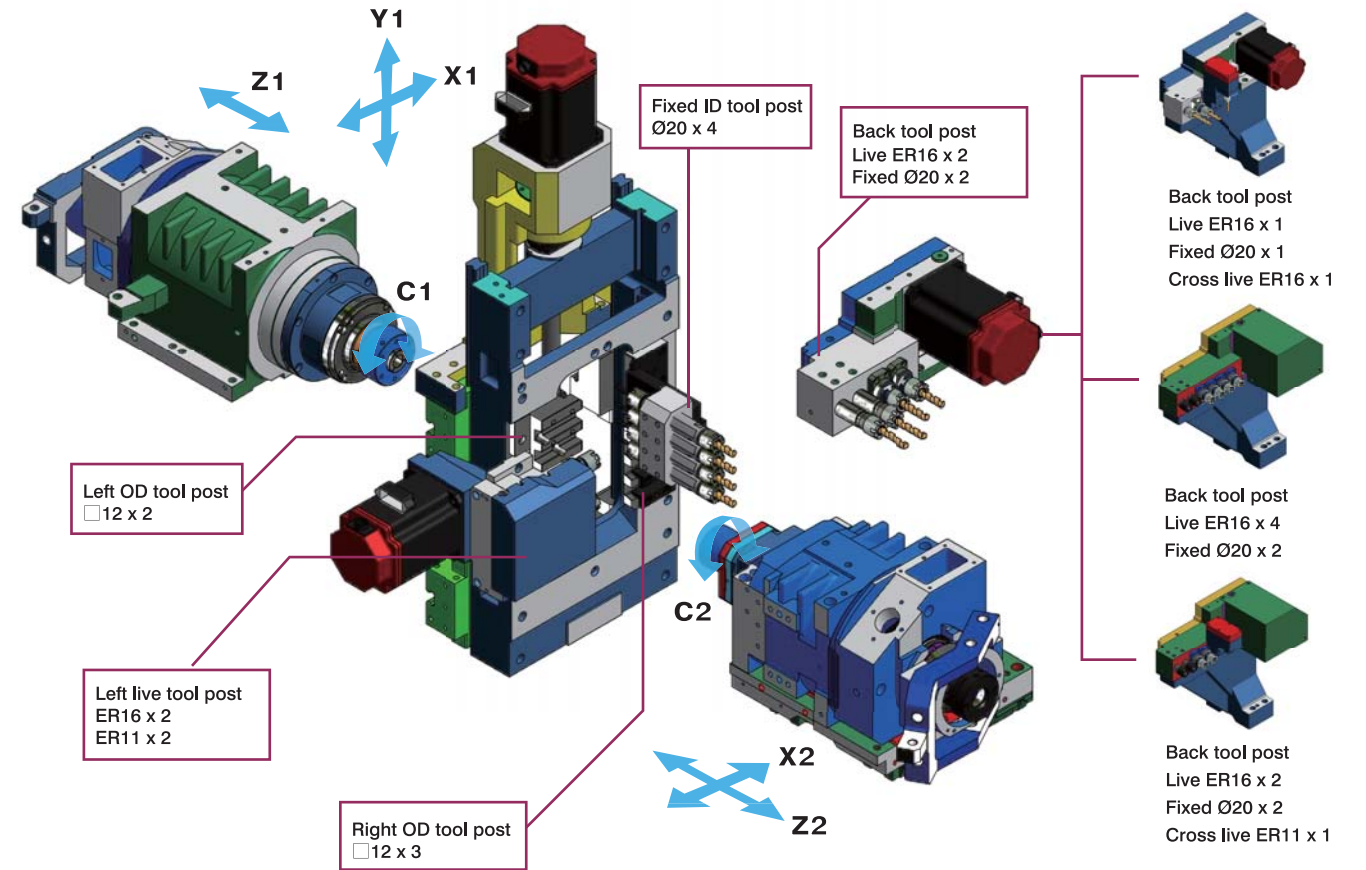

Milling zone S-125

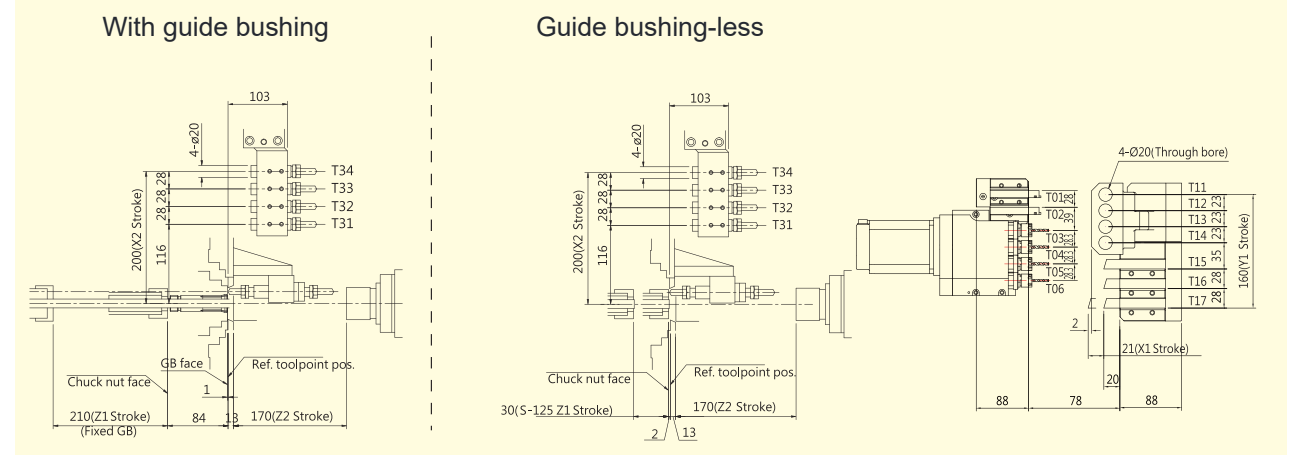

SPECIFICATIONS

MODEL	S-125	S-205N	S-206	S-265	S-325	
Machining capacity	Bar stock diameter at main spindle	1~12	3-20	8-26	8-32	
	Max. bar diameter at back spindle	12	20	26	32	
	Max. machining length	170mm (Direct motor-driven guide bushing) 80mm (Mechanical-driven guide bushing) 250mm (Fixed guide bushing) 30mm (Guide bushing-less)	170 mm (Direct motor-driven guide bushing) 80 mm (Mechanical-driven guide bushing) 250 mm (Fixed guide bushing) 45 mm (Guide bushing-less)	210 mm (Direct motor-driven guide bushing) 80 mm (Mechanical-driven guide bushing) 250 mm (Fixed guide bushing) 46 mm (Guide bushing-less)	320 mm (Direct motor-driven guide bushing) 50 mm(Guide bushing-less)	320 mm (Direct motor-driven guide bushing) 50 mm(Guide bushing-less)
	Max. drilling / tapping diameter of main spindle	Dia.8mm / M6	Dia. 10 mm / M8	Dia. 10 mm / M8	Dia. 12 mm / M10	Dia. 12 mm / M10
	Deep hole drilling	-	-	Dia. 8 mm	Dia. 10 mm	Dia. 10 mm
	Max. drilling / tapping diameter of sub spindle	Dia.8mm / M6	Dia. 8 mm / M6	Dia. 8 mm / M6	Dia.10 mm / M8	Dia. 10 mm / M8
	Max. drilling / tapping diameter of cross tool	Dia.6mm / M5	Dia. 6 mm / M5	L side: Dia. 6 mm / M5 ; R side: Dia. 8 mm / M6	L side: Dia. 8 mm / M6 ; R side: Dia. 8 mm / M6	L side: Dia. 8 mm / M6 ; R side: Dia. 8 mm / M6
	Max. drilling / tapping diameter of back tool	Dia.6mm / M5	Dia. 6 mm / M5	Dia. 6 mm / M5	Dia. 8 mm / M6	Dia. 8 mm / M6
Max. mountable slitting saw	Dia. 30mm	Dia. 30 mm	Dia. 30 mm	Dia. 45 mm	Dia. 45 mm	
Speed	Main spindle	200-12000 min-1	200-10000 min-1	200-12000 min-1	200-10000 min-1	200-8000 min-1
	Back spindle	200-12000 min-1	200-12000 min-1	200-12000 min-1	200-10000 min-1	200-8000 min-1
	Rotary guide bushing	200~12000 min-1 (Motor direct-drive) 200~8000 min-1 (Mechanical-drive)	200-10000 min-1 (Motor direct-drive) 200-8000 min-1 (Mechanical-drive)	200-12000 min-1 (Motor direct-drive) 200-8000 min-1 (Mechanical-drive)	200-10000 min-1 (Motor direct-drive)	200-8000 min-1 (Motor direct-drive)
	Cross / Back tool	200~5000 min-1	200-5000 min-1	200-8000 min-1	200-6000 min-1 (Standard: 4800 min-1)	200-6000 min-1 (Standard: 4800 min-1)
Tool	Mountable tool number		21	28 (Std) / 39 (Max.)	27 (Std) / 39 (Max.)	27 (Std) / 39 (Max.)
	OD tool shank	12 X 12 X 85mm	12 x 12 x 85 mm	12 x 12 x 100 mm	16 x 16 x 100 mm	16 x 16 x 100 mm
	ID tool shank	Dia. 20mm	Dia. 20 mm	Dia. 22 mm	Dia. 25 mm	Dia. 25 mm
	Chuck of cross live tool	ER11 X 2 ER16 X 2	ER11 x 2 ; ER16 x 2	L side: ER11 x 2, ER16 x 1 R side: ER16 x 2 (Opt.)	L side: ER16 x 3, ER20 x 1 R side: ER16	L side: ER16 x 3, ER20 x 1 R side: ER16
	Chuck of back live tool	ER16 X 2	ER11 x 2	ER16 x 4 (Opt.)	ER16	ER16
	Chuck of back fixed tool	ER16	ER16	ER 16	ER16 (Opt. ER20)	ER16 (Opt. ER20)
	Chuck of deep hole drill	-	-	ER 16	ER16	ER16
	OD tool number	5	5	5	L: 5 ; R: 7	L: 5 ; R: 7
	Face fixed ID tool	4	4	5	5	5
	Back fixed ID tool	4 (Mounted at face/back ID tool post) + 2 (mounted at independent back tool post)	4 (Mounted at face / back ID tool post) + 2 (mounted at independent back tool post)	5	5	5
	Cross live tool	4	4	4	L side cross live tool: 4 ; R side cross live: 3	L side cross live tool: 4 ; R side cross live: 3
	Back live tool	2	2	4 (Fix) + 4 (Live)	4	4
	Face deep drill tool	-	-	2	2	2
	Rapid feed rate	30M/min (X: 24 M/min)	30 M / min (X: 24 M / min)	30 M / min (X: 24 M / min)	30 M / min (X: 24 M / min)	30 M / min (X: 24 M / min)
	Motor	Main spindle motor	2.2/3.7 Kw (Con./15min)	2.2 / 3.7 Kw (Con. / 15 min)	2.2 / 3.7 Kw (Con. / 15 min)	3.7 / 7.5 Kw (Con. / 10 min)
Back spindle motor		1.5/2.2 Kw (Con./15min)	1.5 / 2.2 Kw (Con. / 15 min)	1.5 / 2.2 Kw (Con. / 15 min)	2.2 / 3.7 Kw (Con. / 10 min)	2.2 / 3.7 Kw (Con. / 10 min)
Cross tool motor		0.5 Kw	0.5 Kw	L side: 0.75 Kw ; R side: 1 Kw	1 Kw	1 Kw
Back tool motor		0.5 Kw	0.5 Kw	1 Kw	1 Kw	1 Kw
Direct drive rotary guide bushing		0.75/1.1 Kw(Con./10min)	0.75 / 1.1 Kw (Con. / 10 min)	0.75 / 1.1 Kw (Con. / 10 min)	2.2 / 3.7 Kw (Con. / 10 min)	2.2 / 3.7 Kw (Con. / 10 min)
Axes motor		X1, Y1, Z1, X2, Z2 - 0.5 Kw	X1, Y1, Z1, X2, Z2 - 0.5 Kw	X1, Y2, Z1, X2, Z2 - 0.5 Kw ; Y1 - 0.75 Kw	X1, Y1, Z1, X2, Z2 - 0.75 Kw	X1, Y1, Z1, X2, Z2 - 0.75 Kw
Coolant pump		0.75 Kw	0.75 Kw	0.75 Kw	0.75 Kw	0.75 Kw
Lubrication pump		0.011Kw	0.011Kw	0.011Kw	0.011Kw	0.011Kw
Hydraulic pump		-	-	-	-	0.75 Kw
Spindle cooling oil pump		0.19 Kw	0.19 Kw	0.19 Kw	0.19 Kw	0.19 Kw
Axes travel	X1	84 mm	42 mm	124 mm	142 mm	142 mm
	Y1	160 mm	161 mm	280 mm	348 mm	348 mm
	Z1	250 mm	250 mm	290 mm	320 mm	320 mm
	X2	400 mm	200 mm	340 mm	370 mm	370 mm
	Y2	-	-	60 mm	-	-
	Z2	170 mm	170 mm	300 mm	335 mm	335 mm
Miscellaneous	Machine weight	1700 Kgs	1700 Kgs	3700 Kgs	3500 Kgs	3500 Kgs
	Power source requirement	11 KVA	11 KVA	14.3 KVA	21.4 KVA	22.5 KVA
	Compressed air requirement	≥ 4 kg / cm2	≥ 4 kg / cm2	≥ 4 kg / cm2	≥ 4 kg / cm2	≥ 4 kg / cm2
	Air consumption	≥ 30 NL / min	≥ 30 NL / min	≥ 30 NL / min	≥ 100 NL / min	≥ 100 NL / min
	Coolant tank capacity	115 L	115 L	180 L	180 L	180 L
Machine size	1640 x 1080 x 1700 mm	1640 x 1080 x 1700 mm	2300 x 1400 x 2000 mm	2150 x 1280 x 1930 mm	2150 x 1280 x 1930 mm	

※THE SPECIFICATIONS ARE SUBJECT TO CHANGE WITHOUT PRIOR NOTICE.

STANDARD ACCESSORIES:

1. Main and back spindle sleeve (for round bar machining)
2. Door interlock
3. Coolant flow switch
4. Spindle cooling unit
5. Work catcher and work box
6. Automatic power shut-off
7. Back spindle air purge
8. Manual pulse generator
9. Bar feeder interface
10. USB port / CF card port / RS232 port / Ethernet port
11. Software cut-off check
12. Guide bush-less holder
13. Long part discharge
14. Work light and 3 tiered warning lamp set
15. Tool box with tools and manuals

OPTIONS:

1. Hydraulic magazine type bar feeder
2. Oil mist collector
3. Thread whirling attachment
4. High pressure coolant system
5. Chip conveyor with bucket
6. CE mark
7. Transformer

Floor Space

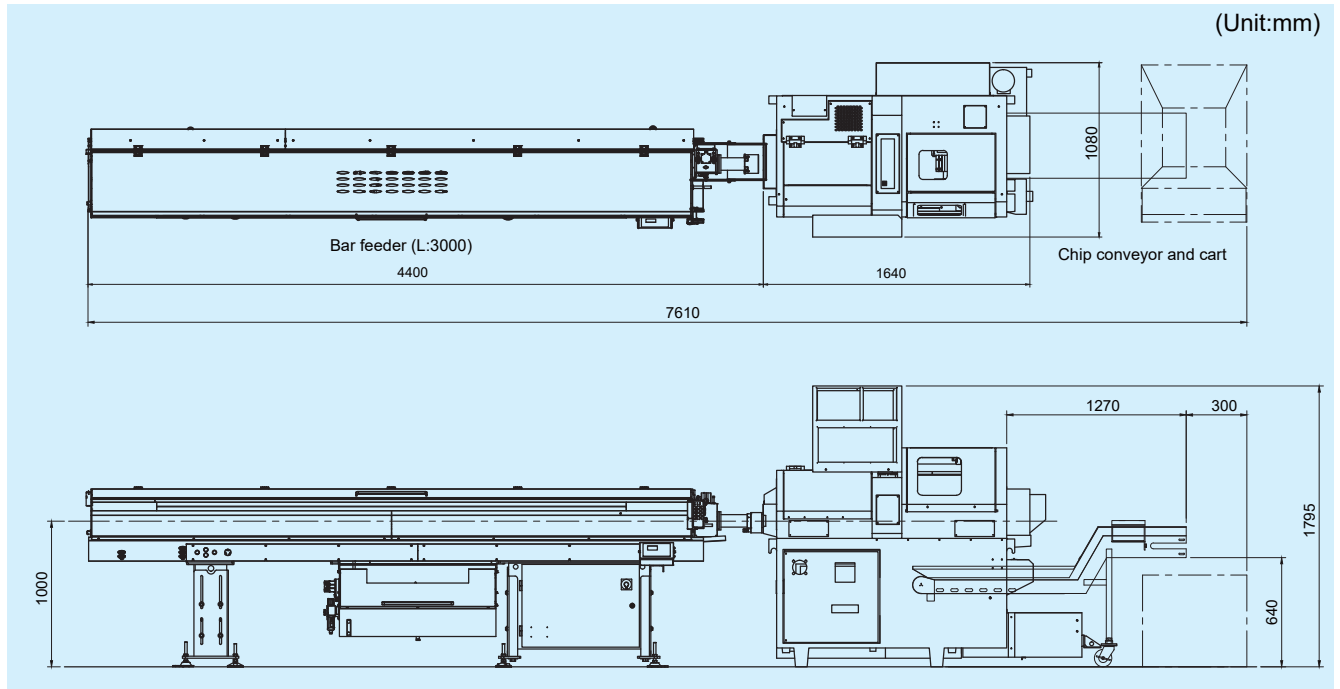

Tooling Zone

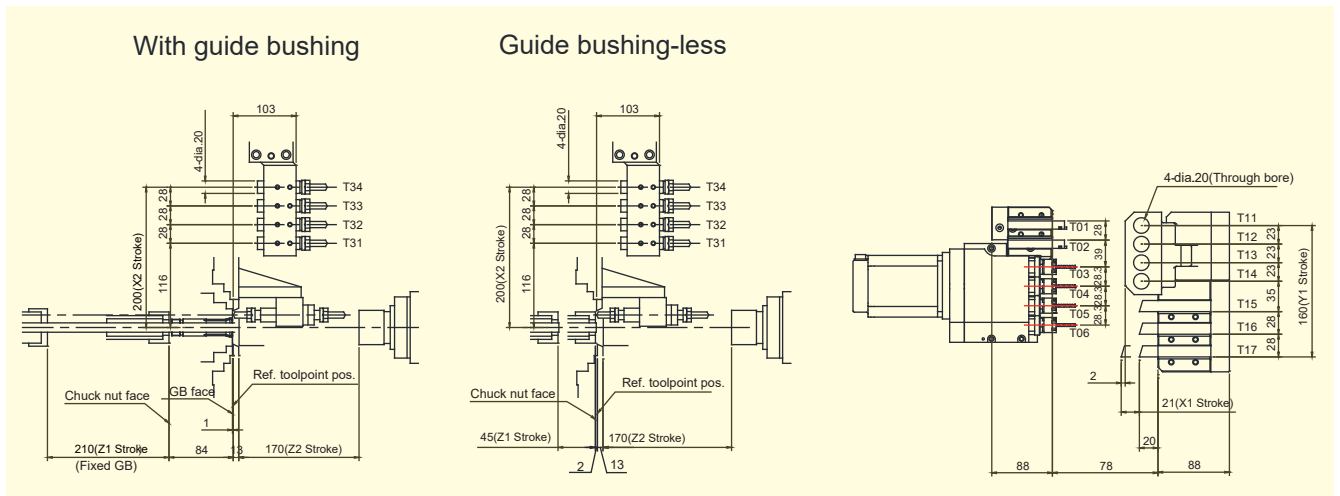

Standard tool post layout

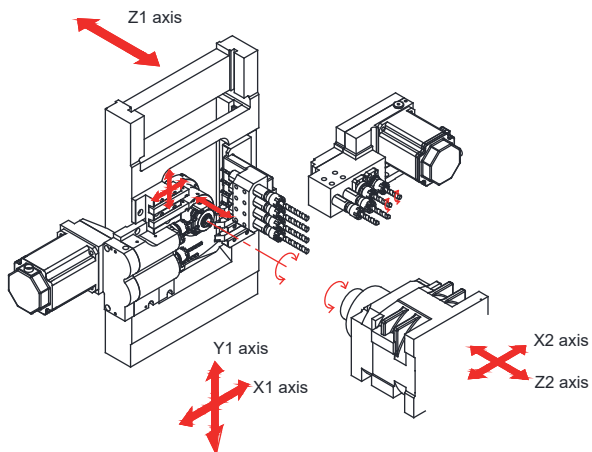

Features

- Direct motor driven rotary guide bush
- Guide bush-less machining is available
- 4 cross live tools for cross drilling, tapping, milling on Y axis

CNC-TAKANG CO., LTD.

No. 72, Alley 7, Lane 98, 1st Road, Taichung Industry Park, Taichung 40767, TAIWAN
 FAX: +886-4-2359 6064 E-mail: takang@ms17.hinet.net
 TEL: (04)2359 6056 Web site: www.cnctakang.com.tw